

3N-0405-F Controller

INSTRUCTIONS

- A: PERFORMANCE and SPECIFICATIONS
- B: DESCRIPTION of PARAMETERS
- C: PARAMETERS LIST
- D: TERMINALS WIRING DIAGRAM
- E: WIRING WITH FEEDER
- F: WIRING WITH LOSS-WEIGHT SCALE
- G: STATION WITH TOUCH SCREEN
- H: APPEARENCE



三恩 SUNEN ELECTRONIC

SHANDONG SUNEN: 0536- 3152451, 3152452, 3152453

BEIJING SUNEN: 010-88900618, 88900718, 88900318

GUIYANG SUNED: 0851-4850733

www.3n2000.com

Dear sir or madam :

It is grateful for you choose our 3N-0405series of devices. We will try our best to offer best quality of service.

Please read this manual carefully before you start to operate the system. If there is any problem or something you think to be uncertain, please consult with our technical personals if anyone is there, or consult our company by telephone.

We will be appreciated very much if you give us your opinion about improvement during your usage. We will keep doing efforts to update and perfect our products.

Original Password: 123456

You must keep password in save hand after you change it to prevent from getting in troubles!!!

Chapter one- Prelude

1. Safety Guidance

Warn Attention

- A、Independently and firmly ground wire. It is strictly prohibit connecting ground line to nil of power supply. It is also strictly prohibit sharing ground line with other electrical equipment.
- B、It is strictly prohibit sharing power supply with other large power and start frequently equipment.
- C、Protect the panel of the device from forcedly scraping or high temperature.
- 1. D、Not allow opening the cover of the device except by service person.
- E、Must pull of the plug of Power Supply before open the cover of the device.
- F、Firmly wire point of the ground line.
- G、With continuous improvement, please read carefully the “Supplement and Description for New Function” if it is attached .

2. SUMMARIZE

3N0405 controller used for belt scale and other weighing system. It is qualified with many kinds of mechanical conveyor. It has 3-channel analog input-outputs. It is easy to join the DCS (digit control system) and PLC control system.

PERFORMANCE

- A、With industry grade CMOS chip, system stable and reliability.
- B、Password protect important paraments from being random ateration.
- C、CPLD programmable chip, imported from Unite State.
- D、Ambient temperature: 0℃~45℃
- E、Measure precise: Better than 0.1%
- F、Display/Keyboard: 8digits +7bit LED, 22-key plain keyborad, working state indicators.
- G、Control variety types of measuring unit.
- H、Fully photoelectricity isolation with input and output for both switch and analog.
- I、Multi-loop of input-outputs for analog and switches.
- J、Pulse input signal fro belt speed.
- K、Swith input for Run, stop, add-up permit and faulty aware.
- L、4~20mA analog input for goal setting (Fully isolated).
- M、4~20mA analog output for current flow. (Fully isolated) .
- N、Pulse output for sub-total (Contact output) .
- O、Switch outputs: Alarm, Higher, Lower, Run and Ready.
- P、Cantact inputs: Run (Normally Open) ,Stop (Normally Close)、Add-up permit (Normallyopen)、Faulty Aware (Normaaly-open) .
- Q、Print report (optional).

SPECIFICATIONS

- A、Power Supply: AC220V±10% 30W。

- B、Feeding control output: DC 0~5V。
- C、Pre-feeding control output: DC 0~5V。
- D、Load cell: supply: DC10V/120 mA ; input signal: 0~62.5mV 。
- E、Analog input for setting control target (Fully isolated): 4~20mA。
- F、Analog output for current flow (Fully isolated): 4~20mA。
- G、Pulse output for sub-total (contact output): 120V、1A。
- H、Contact output: Macheanical contact, 36V、1A。
- I、Pulse input for belt running speed: 0~2000Hz, NPN、DC12~18V。
- J、PROFI BUS and RS485communication interface , Distance: 1200m。
- K、LED1 display: current flowXXXX.XX Kg/minute or XXXX.XX ton/hour , range: 0~9999.99Kg or 0~9999.99 ton.
- L、LED2 display: Total XXXXXXX ton, range: 0~999999 ton.

Terminals on Back

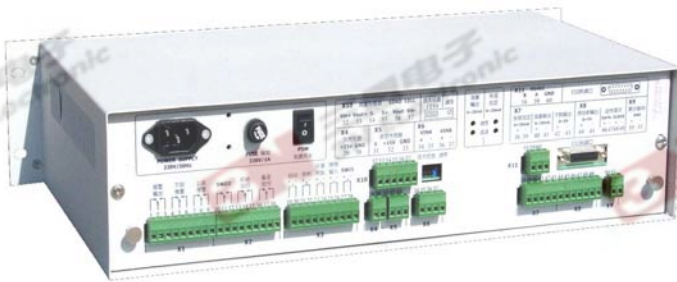

Front of Controller



Chapter Two – Panel

1. Display Module

3N0405 panelg have two display sections. DISPLAY1 (Big display) is a 8-digit LED.

Display 2 is a 7-digit LED(small display).

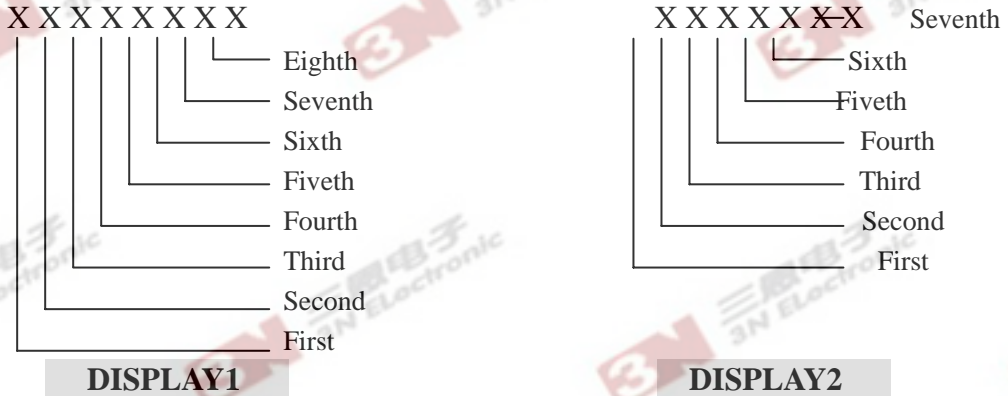

Display 1: It normally displays current flow unless having a paramant modify operation. In that case, the first two LEDS display the title of parameters like ‘P1~P8、H0~H5、C0~C8、A0~A9 or E0~E9; And form the third to lowest it display the real value of certain parameter. The third one is the highest digit of the parameter and the lowest one is the lowest digit of the parameter.

Display 2: It displays the integral part of total. The first one is the highest digit of the total and the seventh is lowest digit of the total. The total show accumulating increasing only when terminal X3 (23、24) in close state. The unit of total is ton.

2. Keyboard



Reset: Waterever situation the system is, press this key result to system get into initialization procedure. After display model and type, system asks for a password. Get password input, system will display current flow and wait further command.



Run/Stop: Press it result system run when system is in stop state and otherwise, Press it result system stop running when system is in running state. Only effective in cese of “C0=0”

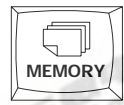

Password Input: Press it in anytime password iput needed. “U=====” displayed and wait to press 6-digit password from numeral keyboard one by one.

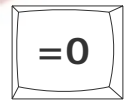

Total Clear: Locate parameter p2, display1 show as “P2 xxx.xxx”, press it will reset total to be zero(0) and display show as “P2= 000.000”. Display2 show as 0000000 also.



Para group: Pressing it continuously, display1 will circularly show the first parameter of every group.

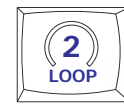

Backwards: It is same with “LOOP1” only in opposite direction of circulation.

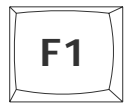

Return: During parameter modify, press it result to return normal state. That is show current flow.

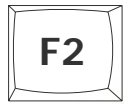

Move Cursor: Cursor means choosed digit twinkling. Press it change cursor positin. Number can be altered only when it is twinkling. Cursor move from highest digit to lowest digit.



Increase: Pressing it circulatory displays all parameters of the certain group located by “Loop1” or “Loop2”.



Decrease: Same as last key “Increase”, backward circulation.

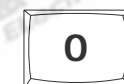

.....



Numeral keys



Enter: After parameter modify, must press “enter” key to inform system save the parameter and make the parameter effective.

3. 11 INDICATORS :

- a. **POWER:** Supply indicator, on when power on.
- b. **RUN:** Running indicator, on when system is running.
- c. **ALARM:** Alarm Indicator. On when alarm happening and off when alarm release.
- d. **MAX:** Over High limit indicator, on when Current Flow over high limit (A2) and off when Flow normal.
- e. **>0<:** Zero Procedure Indicator, on during Zero Procedure start and off when end.
- f. **MIN:** Low limit indicator, on when Current Flow get lower than low limit (A3) and off when Flow normal.
- g. **RS485:** Communication indicator, wink during communication and off when communication stop.
- h. **OUTSIDE:** Remote Control Indicator, on when C0=1 Remote Command Way select meanwhile Keyboard Indicator off.
- i. **KEYBOARD:** Panel Control Indicator, on when C0=0 Panel Command Way select meanwhile Outside Indicator off.
- j. **FUN2:** Spare
- k. **FUN1:** Spare

Chapter 3 – One By One Guide

1. Check and ensure all terminals connect well. Check and ensure all mechanical parts in good condition.
2. Power on or press key “reset” while already power on, the name of device “3N0405-F” display on panel. A beep is heard after a while, Screen display 6 characters “≡ ≡ ≡ ≡ ≡ ≡” to hint user to input 6 digit password. If do not need inputting right password, press “Enter” directly. Right input password make user have a privilege to modify all parameters. If not, only few parameters could be modified. The original password is “123456” when delivery.
3. Determine the type of feeder, read “**Parameter Modify Way**” in chapter 4
C6=0, Speed Constant Feeder, belt running at a constant speed.
C6=1, Speed Vary Feeder, a speed detector will measure belt running speed.
4. Modify password from original “123456” to user own password. That is modifying parameter A9. Protect well your new password (better to take down on a paper record). If you forget your own password, you have to send the device back to our company to initialize it. That is a big trouble for you !!!
5. Read Chapter 4 and Check and set all parameter. Please read the “**Parameter Modify Way**”
6. Adjust mechanical body of feeder according corresponding mechanical manual.
7. Do zero precess to determine parameter P4 and do calibrating process to determine parameter P5. See Chapter 4 Px group parameters
8. Clear accumulating total. See chapter 4, Px group parameter, P2.
9. Press key “run/stop”, trial the device at a small quantity of materials. That is let P1= a small target, which make belt running at a low speed. The target P1 can gradually be increased until the designed capacity. During this process, watch out carefully and switch off immediately whenever anything abnormity happen. Specially caution personal security.

Chapter 4 Description of Parameters

Please Read Careful “Parameter Modify Way” before you prepare to modify a parameter. !!!

Parameter Modify Way (Input On Keyboard)

This method is generally used in all parameters which need to be setting from keyboard.

1. Most parameters need to have a privilege that obtain by inputting a right password. Not have the privilege means that those parameters can access but not a glint cursor, means which can not be modified.
2. To obtain a privilege, way 1 is when device power on and display “=====” to ask for a password, then orderly press key of 6 bits password.
3. To obtain a privilege way 2 is pressing key “Memory”, system will display “=====” to ask for a password, then orderly press key of 6 bits password.
4. When device dilievery, the original password is “123456”.
5. Press key “LOOP1” and “LOOP2” to find the first parameter of every group. Both two keys go through out all groups of parameters but in a opposite direction, which makes easy to find the needed group.
6. Locate the needed group, press ket “Inc” and “Dec” find right parameter in this group that you like to set.If you have the pribilege, you got a flash cursor at the highest bit of parameter.
7. Press key “F2” to move the cursor into the position need to be modified. And then just press the number key.
8. The Key “Enter” must be press to finish this time modification. That is very important. That inform system the new parameter need to save and make it effective. Without the “Enter” key pressing means alteration for this parameter invalidation. Please must keep in mind !!!

Px Group Parameters

P1: Control Target

0~9999.99 Kilo / Minute (C9=0)

0~9999.99 Ton / Hour (C9=1)

0~9999.99 Kilo / Second (C9=2)

0~9999.99 Gram / Second (C9=3)

This parameter is the goal that system control to reach. There are three ways to define the parameter.

1. In case of C1 = 0 , input from keyboard,
2. In case of C1 = 1, determined by analog input. Terminal X7(38 and 39), 4~20mA, corresponding Value range define by Parameter A0
3. Parameter C1 = 2 , determined by Communication.

P2: Decimal fraction of Total Output

0~999.999, Kilogram, Only for display, can be clear from keyboard.

This parameter shows the decimal fraction of total output. The integer part of total show on panel, The display 2.

The terminal "Accumulate Permit",X3[23、24] must be close for system began to addup the output.

Clear Total: In case of stop, show parameter "P2", press key "= 0".

P3: Value for Control Analog output

0~1023, can be modified, input from keyboard.

While system start run, feeding output will start from this value. During system running, it shows executor output. It is corresponding to output voltage 0--5V.

P4: Zero Value

0~65535, Default= 600。

P4 is the value that should be the reading of analog input for load cell when no materials on the belt. The reading of analog input for load cell can be seen on parameter H0 and H1. System has auto zero function and users also can set the zero value manually from keyboard.

If the device type is constant-speed belt feeder, that is C6=0, zero process will be auto proceed before every time start running.

If the device type is vary-speed belt feeder, that is C6=1, no zero process happened when starting. Users must begin a Zero Process when it is needed. Users also can define zero value self and input the value from keyboard.

The time of zero process lasting is determined by parameter A7. A7 should be defined exactly that can make belt going a (or several) entire circle.

A. Auto Zero Process:

1. Press key "Run/Stop" to let the belt running so that the materials on the belt clean up.
2. Set parameter A7, Time Section of Zero Process. A7 can be determined by measuring the interval of belt going one or more than one entire circles.
3. Locate P4 and press key "Enter" to command system to begin Zero Process. Zero Indicator on and analog input of Loadcell shows.

When the Time Section of Zero Procedure (A7) runs up, the process finish and the Zero Indicator off and new Zero Value save and become effective.

Note: Must not touch the any part of feeder during the Zero Process.

P5: Calibrate Factor:

0~9999.99

Calibrate Factor is a value that is needed to calculate the quantity of material passing through the weighing section in a piece of time. This factor directly determines the precise. So it is strongly asked that Calibrate Factor must be turned out by Calibrating Procedure before the feeder put in operation. And it is also strongly asked that Calibrate Procedure must be carried out after every time mechanical alteration happened.

1. Must do Zero Procedure first before Calibrating Procedure (reference with Parameter P4).
2. Find parameter P5. Original Calibrate Factor can be seen.

Press Key “Enter”, the procedure begin and display turn into 0000.00 (Kg) that means material add up in this calibrate process.

If the controlled feeder is Speed-Constant (C6=0), the belt or other running parts must be started running first.

3. Get a container under the discharge in order to collect the materials.

Press Run/Stop and Run belt, and show accumulative material quantity through the weighing section.

Manually adjust the execution unit (Frequency convert or control supply or something like) to drive material (or weights) passing the belt and go into the container.

4. Wait until the timer (A8) runs out, system automatically stops. If you feel got enough materials in the container, you can manually stop feeding by press key Run/Stop again. Add up stop also. However if the controlled object is a Speed-Constant belt feeder (C6=0), must wait the belt clear up before you stop the running belt.

By then system displays calculated quantity.

5. Weighing the all material collected by the container.

If this weight is exactly equal to the value displayed by system, which means the old Calibrate Factor saved in system is all right. Just keep it and quit the Calibrate Process.

6. If this real weight in container different from the value displayed by system, it means the old Calibrate Factor need to be altered. Input the real accumulated weight and press Key “Enter”. The system will calculate a new Calibrate Factor and display and save it. Do the Calibrate Process again using this new Calibrate Factor.

Note:

- Parameter C0 must be zero in order to do the Calibrate Process. C0=0 (Command on keyboard).
- Prohibit touching any part of the feeder during the Calibrate Process.
- Zero Procedure must be done before Calibrate Procedure and suggest to do Calibrate Procedure more than one time to get high system precise.
- Before do Zero and Calibrate, It must be done to adjust the parallelism of the weighing rollers. See mechanical manual.

P6: P Value: Proportion factor in the PI-arithmetic

0~99.99, normally 1~60, default=10.

It is P-factor of the PI-arithmetic, a model of software. P-factor is proportion factor and determines the change scope of output regarding to the gap between the target and real flow (you can see the output value in case of selecting P3). The larger this value, the better following characteristic with Control Target. Unreasonable large of this P-factor will result to the over-regulation and the output oscillation. Contrariwise, too small P-factor will drag down the trace paces and make the system difficult to get up to the Control Target.

P7: T value: Integral factor in the PI-arithmetic

0-99.99, General 3~20, Default P7 = 5

It is T-factor of the PI- arithmetic, a model of software. T-factor is integral factor and determines the change scope of output regarding to the gap between the real flow and last real flow (you can see the output value in case of selecting P3). The larger this value, the better stability of system. Unreasonable small of this T-factor will result to the frequently-regulation and the output oscillation. Contrariwise, too large T-factor will drag down the trace paces and make the system difficult to get up to the Control Target.

Note:

- The purpose of iterative modifying the P and T value is to guarantee the smallest rebound of the real flow around the Control Target.
- If the fluctuating flow result from the mechanic problem, it is useless to modify the P and T factor.
- It must be done to re-define the P and T value in case the mechanical alter.
- P and T value is the key of the control precise. Make sure to determine the appropriate P and T.

P8 : Flow Smooth Factor

0-100, Default P8 = 1

This parameter restrain that displayed Flow fluctuate madly, only in case the mechanical incurable running unstable. The Bigger the value is the slower the display change.

The value does not affect any function but Flow display.

P9 Inner Accumulative Flow Error

0-9999.9, No Default

This parameter could not be modified by user. Sometimes, a large accumulative error occur inner system because of mechanical faulty which make materials block or collapse. So the real accumulative production will get far away from goal production. If Users set the parameter CC=1 and start flow trace function, P9 will display the accumulative error of production. As soon as the mechanical running stable and normal, system will adjust control pace and this error display will turn to be zero.

PP: Belt Speed

1. C6=0 (Speed constant), parameter PP= Duration time of belt running one entire circle, Unit Second.
2. C6=1 (Speed Vary), parameter PP= Pulses while belt goes 1 meter, unit pulse/meter.
3. Measure way: Show this parameter, start belt running, make a mark on the surface of belt(for instance: joint of belt). Press key "Enter" when the mark move to a certain position, have accumulated pulse numbers shows, when the mark run a entire circle arrive this same position again, press key "Enter" again, measure finish, system will show the result.
3. Before measure PP, it must be done to set the parameter AB, the length of belt.

Hx Group Parameters

This is a group of real time data, only can be check, not allow to modified.

H0: Analog Input of Load Cell

0—65535, it is corresponding to range of load cell.

Weighing signal generate form materials on the weighing section and scale body

H1: Compensated Analog Input

0—65535, it is corresponding to range of load cell.

As a load, load cell make its supply voltage change and effect input value. So some compensate arithmetic needed to correct this error. H1 is the result of this arithmetic. This arithmetic do only in cese parameter $CB=1$ and parameter $E4$ and $E5$ have been set correct. If $CB=0$, H1 has save value with H0.

H2: Power Supply (+) of Load Cell

0—4095, it is corresponding to supply (+) of load cell.

When supply (+) gets lower, the value gets decreased.

H3: Power Supply (-) of Load Cell

0—4095, it is corresponding to supply (-) of load cell.

When supply (+) gets higher, this value gets increased.

H4: Pluses for speed

0~2000, it is corresponding to 0-2000 Hz.

Pulse comes from speed detector. This value higher means the scale running faster. This value lower means the scale running slow.

H5: Belt Running Speed

XX. XXXX Meter / Second

The valud shows the meters of belt going duration one second.

H6: Load on Belt

XXXX.XX, unit: Kilogram

To Belt scale, this value shows the weight of material on weighing section.

To Bucket scale, this value shows weight of material in the bucket.

H7: Analog Input for Target Setting (Maintenance Usage)

0 — 4096, it is corresponding to Analog input (4-20mA or 0-10V)

This analog input determine the target of the system, usually comms from remote controlling center).

H8: Switches Input ((Maintenance Usage)

0~XXXXXX。

Each bit presens one input, 0= off, 1=on.

Cx Group Parameters

C0: Start / Stop Way

C0=0: Local, command from keyboard

C0=1: Cabinet Switch Control (Analog Remote Control)

C0=2: Remote Communication (Digital Remote Control)

This parameter sets the way that system starts or stops running.

1. If C0=0, press key "RUN/STOP" on panel to start or stop system.
2. If C0=1, Start or stop control by switches on cabine, signals go into system through terminals of back of 0405. Terminal X3[19、 20] close is for start command. Terminal X3[21、 22] disconnect is for stop command. Only in case of terminal X3[21、 22] is in close, the start command is effective.

Note: Start terminal is normally open contact. Stop terminal is normally close contact.

3. If C0=2, Start and stop action control by remote center by communication.

Note: By communication, parameter A5 is communicatin address. (see parameter A5)

C1: Target Setting Way

C1=0: Input on Panel

C1=1: Analog Input

C1=2: Communication

C1: Target (P1) Define Way

Value: 0=Panel, 1=analog input, 2=Remote Communication

1. C1=0, Parameter (P1) input from keyboard, Reference Parameter P1
2. C1=1, Parameter (P1) is determined by analog input, terminal raft X7, terminals 38 and 39, signal 4-20mA.
3. C1=2, Parameter (P1) is determined by communication with central control room. Need to know the main control system of the main service station. It is must done that local device address (C8) set.

C2: Remote Analog output Select (terminals 40 and 41)

Value: Always = 0

C3: Alarm Limit Condition

C3=0: Parameter A2 and A3 show as percentage, Unit %

C3=1: Parameter A2 and A3 show as a real value with same unit as Control Target (P1).

Refer to parameter A2 and A3

C4: Stop with Alarm

C4=0: Non stop in case alarm occur. System still running and output alarm signal.

C4=1: In case of an alarm happen, system insists on running a section of time that depend the value of A4 and then stop.

C5: Add up Way

C5=0: Do Accumulative Total (P2) all time no matter system running or not. It is considerable while users manual drive feeding sometime

C5=1: Do Accumulative Total (P2) only when system is running.

C5=2: Do Accumulative Total (P2) only when system is running and flow output always =0 .(X7[40,41])

C6: Set Controlled Scale

C6=0: Controlled object is Speed-Constant Belt Scale. No speed signal. Controlled executor is feeding unit. Zero Process is automatically engaged before it is to run. Refer to P4

C6=1: Controlled object is Speed-Vary Belt Scale with speed signal. Controlled executor is Frequency Inverter

C7: Control Way

C7=0: Control the flow of scale.(3N0405-F)

C7=1: Control the flow of scale with Pre-Feeding function.(3N0405-FY).

C7=2: Only Weighing and do add up (not in this device)

C8: Communication Way

C8=0: 485 Communication.

C8=1: PROFI BUS Communication

C9: Measure Unit (Target, Flow)

C9=0: The unit is Kilogram / Minute

C9=1: The unit is Ton / Hour

C9=2: The unit is Kilogram / Second

C9=3: The unit is Gram / Second

The unit determined by C9 will dominate those parameters like P1, A0, A1, A2, A3, A6 and add up in calibration.process.

CA: Magnify Multiple

0~3, Only can be modified by device service personal.

According various signal range of load cell, choose proper magnify multiple, which produce proper range of digital readings of analog input. That will make system precise get higher. This parameter can only determined by special maintenance personal according hardware condition and not allow to be changed as soon as it is decided.

CB: Compensation Choose

CB=0: Do not apply compensation arithmetic to analog input of load cell.

CB=1: Apply compensation arithmetic to analog input of load cell.

It can be decided by device service personal according hardware condition.

CC: Flow Trace

CC=0: Not flow trace performance.

CC=1: Start the flow trace performance. That is, during a section of time, if accumulative flow largely less than expected flow, which usually occur when materials block, the system will automatically make up the flow. Otherwise, if the accumulative flow largely more than expected one, which usually occur when materials collapse, the system will automatically decrease the flow.

In normal case, set CC=0, do not start this function

AX Group Parameters

A0: Maximum of Target (P1) Determined by Analog Input

1.00~9999.99 Kg / Minute (when C9=0)

1.00~9999.99 Ton / Hour (when C9=1)

1.00~9999.99 Kg / Second (when C9=2)

1.00~9999.99 Gram / Second (when C9=3)

This value is effective only when C1=1, that is Control Target P1 determined by remote analog input come from remote center or somewhere like. The signal gets in through terminal X7 (38 , 39), 4-20mA.

That means, the Control Target (P1) = A0 when the signal is 20mA. And (P1)=0 when 0mA.

For example: If A0=500 Kg / Min, then P1= (reading-4)*500 / (20-4) while signal vary in range of 4-20mA.

Note: In some hardware condition, signal fail to flow in 4-20mA, need parameter E0 and E1 to adjust it (see parameter E0,E1).

A1: Maximum of Current Flow output Corresponding to Analog Output

1.00~9999.99 Kg / Minute (when C9=0)

1.00~9999.99 Ton / Hour (when C9=1)

1.00~9999.99 Kg / Second (when C9=2)

1.00~9999.99 Gram / Second (when C9=3)

A analog output sends out to remote control center (or somewhere like) through terminal X7 (40, 41). It is a 4-20mA signal to present current flow. This A1 defines how much the Current Flow is when the signal should be 20mA.

For example: If A1=500 Kg / Minute, Then, output = (Flow* (20-4) / 500) + 4 while Flow vary in a range of 0-500.Kg

Note: In some hardware condition, signal probably fail to flow in 4-20mA, need parameter E2 and E3 to adjust it (see parameter E2,E3).

A2 /A3: High /Low Limit for Current Flow

1.00~9999.99 Kg / Minute (when C9=0)

1.00~9999.99 Ton / Hour (when C9=1)

1.00~9999.99 Kg / Second (when C9=2)

1.00~9999.99 Gram / Second (when C9=3)

1. When parameter C3=0, A2/A3 presents a percent of the Control Target P1. Default is 20.

For instance: If Flow > P1+A2*P1 then system gives an alarm and higher limit indicator.

If Flow < P1-A3*P1 then system gives an alarm and lower limit indicator.

2. When parameter C3=1, A2/A3 presents a real higher/lower limit of flow. They are have to re-define when P1 change and the A2 must be higher P1.

For instance: If Flow > A2 then system gives an alarm and higher limit indicator.

If Flow < A3 then system gives an alarm and lower limit indicator.

The Alarm output terminal is X1 (1,2,3). The higher limit output terminal is X1(7,8,9). The lower limit output terminal is X1(4,5,6).

A4: Delay for Stop resulting from Alarm

0~9999 Second

While C4=1 (system will stop with alarm), A4 means the time section that system can tolerance running in the alarm condition. If continuous alarm time over the time section A4 then system will automatically stop.

A5: Commucation Address

00~32, use for communication。 Not allow more than one has same address.

A6: Subtotal Pulse Output

1.00~9999.99 Kg (when C9=0)

1.00~9999.99 Ton (when C9=1)

1.00~9999.99 Kg (when C9=2)

1.00~9999.99 Gram (when C9=3)

The system output a pulse to inform the remote a subtotal reached through terminal X9 (50, 51), NPN no power output. The frequency of pulse is not allow to be higher than 1 Hz. For example, A6=2000Kg, one pulse send out for every 2000Kg.

A7: Time Section of Zero Procedure

0~9999 Second

A7 determines how long Zero Procedure last.

Make a mark on the belt. Drive the belt running and take down the exactly interval T which belt running a entire circle need. Set A7 to be n times of the interval T (n=1 to 3).

If A7=0, no zero procedure proceed.

A8: Feeding time of Calibrate Procedure

0~9999 Second

During the Calibrate Procedure, After pressing key “RUN/STOP” and feeding materials through the belt, system will automatically stop the feeding at the moment the time A8 run out.

If wanting to stop feeding before the time run out, press key “RUN/STOP” again to force the system to stop. This parameter normally uses in belt feeder. Because of high speed, materials pass through so quickly that it is too late to operate with keyboard.

If control feeding material by hand, this parameter should be set into a big number, like A8=9999.

A9: Password

000000-999999, 6 digits

Input a new 6-digits Password. You can do this only in case there is a cursor flash, means you have a privilege of modifying parameters.

Just orderly input 6 digits one by one. System will automatically save and renew the password.

Note: Every time reset the system or power on, system will display “≡≡≡≡≡≡” for 10 seconds to wait input the password.

6-digits password orderly input one by one. System will not display anything.

If the password is right, you get privilege of changing all parameters (a cursor flash, include A9 itself) and doing Zero and Calibrate Procedure.

Otherwise, if the password is not right or if input nothing during the 10 second, you only can modify some few of parameters including P1, P3, P6, P7, C0, C1.

If begin inputting passwords but less than 6 digits, system will wait.

Press key  re-input password in any time you need.

Note: When the device delivery, the password is ‘123456’

AA : Adjust Scale of Flow trace

0-99, Unit %, Default =10 (10%)

When CC=1, system start flow trace module. The parameter AA determines the control pace of flow trace.

That means how fast system will eliminate the accumulative error. It is normally set to be 10. Too big value will cause the system unstable.

At: Delay of Run /Stop Command

0-999, Unit: second, Default =10 (10s)

At=0: No delay.

At=XX: When system receive the run or stop command (from keyboard or from outside switch), it will wait XX seconds before it really acts.

Ab: The Length of Belt

0 - 9999.99 Meter. Measure with a ruler and input from keyboard.

Ad: The Length of Weighing Section

0 - 9999.99 Meter. Measure with a ruler and input from keyboard.

AL: Delay from Start to Feed Materials (for Speed Constant Feeder)

0 - 9999 Second

When feeder receive a start command (from both keyboard and remote):

1. Start the belt, output signal terminal X2, Swo3= On
2. If belt fail to run within 2 seconds, send alarm. The alarm signal will desappear when next start/stop command receive.
3. If belt start running, let belt run a duration decided by this parameter **AL**.
4. Then do zero procedure and really start feeding materials.

When feeder receive a stop command (from both keyboard and remote):

1. Stop feeding materials first.
2. Let belt continuo running a duration decidec by **AL** to clear belt.
3. Stop belt. Swo3=off

Typical Wiring Diagram in this application

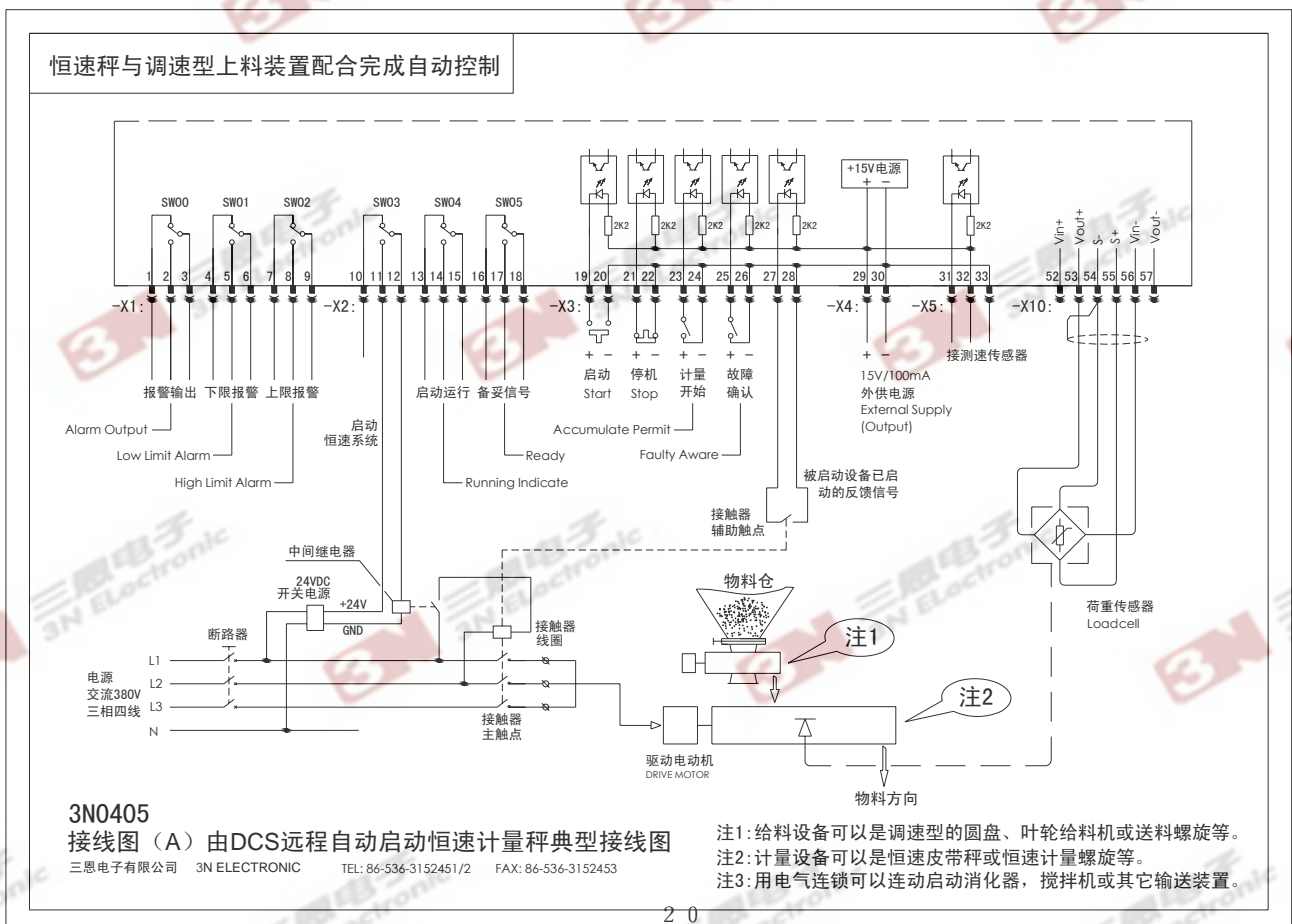

Ex Group Parameters

E0 (E1): EXTERNAL GOAL INPUT MINIMUM (MAXIMUM) ADJUSTER

When parameter $C1=1$, the control goal determined by external analog input (Input channel 1). The signal should be 4-20mA and converted digit value should be 0-4095. However, in practical circuit the actually signal probably is between 0-22mA (or 6-18mA something like) and not able to guarantee to convert into digit value 0-4095. Setting Parameter E0 and E1 can solve the problem.

Determine E0:

1. Set $C1=1$ and $E0=0$
2. Make the input signal minimum and check up the $P1$ (Control Target) that should be zero.
3. If $P1 > 0$ then increase the $E0$ and check the $P1$ again.
4. Repeat the step 3 till the $P1$ exactly equal to 0.

Determine E1:

1. Set $C1=1$ and $E1=4095$, then decide and input Parameter $A0$ (for instance $A0=500$)
2. Make the input signal maximum and check up the $P1$ (Control Target) that should equal to $A0$.
3. If $P1 < A0$ then decrease the $E1$ and check the $P1$ again.
4. Repeat the step 3 till the $P1$ exactly equal to $A0$.

E2 (E3): FLOW OUTPUT MINIMUM (MAXINUM) ADJUSTER

E2 and E3 are set for solving Same problem as above with Flow Output (output channel 1) to guarantee the digit 0-1023 convert into exactly 4-20mA.

Determine E2:

1. Set $E2=0$
2. Simulate input the loadcell and speed signal being minimum and the Current Flow should be zero (0000.00).
3. Check up output (Output Channel 1) that should be 4mA. If it $< 4mA$ then increase the E2, otherwise decrease E2.
4. Repeat the step 3 till the output exactly equal to 4mA.

Determine E3:

1. Set $E3=1023$, and then decide and input Parameter $A1$ (for instance $A1=500$), and set $P4=0$ (zero value=0)
2. Simulate input the loadcell and speed signal making Current Flow equal to or greater than $A1$ (500.00in this case).
3. Check up output (Channel 1) that should be 20mA. If it $> 20mA$ then decrease the $E3$, otherwise increase $E3$.
4. Repeat the step 3 till the output exactly equal to 20mA.

E4: Factor Use in Compensation Arithmetic for Load Cell

0 – 4095, Set only by device service personal.

E5: Factor Use in Compensation Arithmetic for Load Cell

0 -- 65535, Set only by device service personal.

E 6 (E 7): CONTROL OUTPUT MINIMUM (MAXIMUM) LIMITATION

Value: 0-1023

These two parameters limit the range of controlling output and ensure system working in an excellent state. When system running in a good condition, watch parameter P3 (Output value), take down a group of P3 value. E6 could be the smallest one or less than it. E7 could be the biggest one or large than it.

Note: If E7=0, there is zero control output.

E8: Multiple of Calibration P5

0~4, Default=0, set only by device service personal.

Calibration coefficient is so important to measure that it is too big or too small will make against measure precise. The combination of E8 and P5 will obtain a proper real calibration in system.

E8=0, Calibration coefficient =P5

E8=1, Calibration coefficient =P5 * 2

E8=2, Calibration coefficient =P5 * 4

E8=3, Calibration coefficient =P5 * 8

E8=4, Calibration coefficient =P5 * 16

E9: Baud Rate

Select proper baud to be consistent with other device that communicate with.

E9=0: Baud=2400

E9=1: Baud=4800

E9=2: Baud=9600

E9=3: Baud=19200

LX Group Parameter (Special Use by Static Scale, Reference with Supplement Instruction)

These parameters have different meaning in different system. Below is a instance of Loss-weight scale.

L0: Up limit of weight of materials in bucket, load action will stop by this limit.

L1: Up limit of weight of materials in bucket, load action will give alarm and turn to load action by this limit.

L2: Holding duration after load action, make scale to be static state. Unit second

L3: Maximum load duration, If load fail to finish in this time section, it means faulture, give alarm. Unit: second.

L6: Coefficient 1 of arithmetic, the bigger, the slower of control speed, the more stable of ruuning. Otherwise, the smaller, the quicker of control speed, the more vibrate. Unless mechanical structure change, this parameter strongly forbidden not be modified

L7: Coefficient 2 of arithmetic, opposite effection to L6. That is, the small, the slower of control speed, the more stable of ruuning. Otherwise, the bigger, the quicker of control speed, the more vibrate. Unless mechanical structure change, this parameter strongly forbidden not be modified.

L8: Tolerance duration. Unit: Second. If accumulating error exceed the normal accumulating total that should have in this time section, give alarm.

UX Group Parameters (Fix Quantify Feed)

U0: Goal for Fix Quantify Feed

0-9999.99, Unit: ton, Input from keyboard

U0=0, No Fix Quantify Feed function.

U0<>0, U0= tha goal of fix quantify feed. After system start feeding, when accumulating total>= the goal, system will stop automatically.

U1: Accumulating Total for Fix Quantify Feed

0-9999.99, Unit: Ton

It shows the accumulating total feeding after system start. Can not be modify.

t X Group Parameter

t0: Date

Display Format: Year, Month, Date (XX.XX.XX)

Input from keyboard (reference to 3-1. MODIFY MOTHEED FROM KEYBOARD)

T1: Clock

Display Format: Hour, Minute, Second (XX.XX.XX)

Using the combination of the keys “F2” and Numeral to input real time. Must Confirm it and inform system using the key “Enter” after ending the modify process.

T2: Date of Last Turn On

Display Format: Year, Month, Date (XX.XX.XX)

T3: Time of Last Turn On

Display Format: Hour, Minute, Second (XX.XX.XX)

T4: Date of Last Turn Off

Display Format: Year, Month, Date (XX.XX.XX)

T5: Time of Last Turn Off

Display Format: Hour, Minute, Second (XX.XX.XX)

O Group Parameters

O0: Flow Subsection Adjust Function Active/Cancel

When belt runs as a various speed, calculated flow come from same load on belt will show somehow differences. Flow subsection adjust function build for resolve this problem.

O0=0: Cancel this function.

O0=1: Activa this function. Parameters O1-O4 must be set properly before active this function.

All these four parameters limit within 0.9-1.1.

O1: Coefficient 1 of Flow Subsection Adjust

Adjust proportion when flow is less than 25% of maximum flow (A1). Defaul=0.9

O2: Coefficient 1 of Flow Subsection Adjust

Adjust proportion when flow is around 25% of maximum flow (A1). Defaul=0.95

O3: Coefficient 1 of Flow Subsection Adjust

Adjust proportion when flow is around 75% of maximum flow (A1). Defaul=1.05

O4: Coefficient 1 of Flow Subsection Adjust

Adjust proportion when flow is around maximum flow (A1). Defaul=1.1

O5 - O9: Auto Print

There could have 4 times auto print every day. Total will be clear after every auto print action.

O5=0: No auto print

O5=1: Start auto print.

O6-O9 parameters appoint the hour moment of four time print acts

If less than 4 times auto print need, set same hour setting as previous one that is needed.

For instance: Print one time every day at 8 o'clock

O5=1, O6=8, O7=8, O8=8, O9=8

Print two times every day respectively at 0:00 and 12:00

O5=1, O6=0, O7=12, O8=12, O9=12

Print three times every day respectively at 0:00 and 8:00 and 16:00

O5=1, O6=0, O7=8, O8=16, O9=16

Print four times every day respectively at 2:00 and 8:00 and 12:00 and 20:00

O5=1, O6=2, O7=8, O8=14, O9=20

Yx Group Parameters

*Parameters below here for Pre-Feeding function, there are optional function and must set C7=1.

The function of Pre-Feeding is to control the thickness or quantity of materials on the weighing section of the belt and make it closely constant.

Y0: Load of the Weighing Section

0~9999.99 Kg, Real Load of the weighing section on belt, no modifiable.

Y1: Goal of Load of Belt

0~9999.99Kg

This is the goal of Load that is considered to be proper. Larger value means the thicker of materials.

Y2: Proportion Between Analog Input for Loadcell and Belt Load

1~9999.99

This Value is determined only through a manual calibration process.

1. Zero Process (define P4) and Calibrate Process (define P5) must be done.
2. Clear up the belt especially the weighing section..
3. Record the Analog Input for Loadcell (An), taking it as M1
4. Put standard weights on the weighing section, along with the central line of the weighing section. It is best putting the weights well-proportioned from the first roller of the section to the last roller of the section.

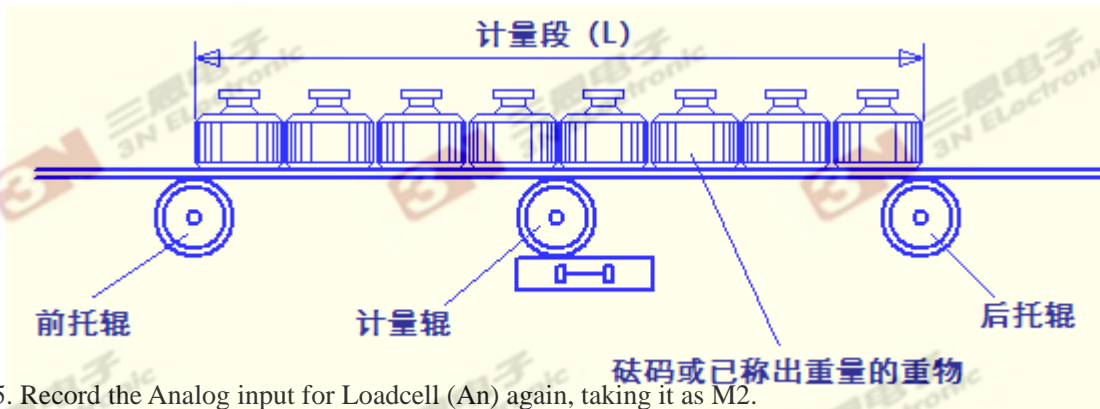

5. Record the Analog input for Loadcell (An) again, taking it as M2.

6. According the formula: $H2 = (M2 - M1) / \text{total of weight}$. The unit of weight is Kg.

Input H2 from keyboard (reference to 3-1. MODIFY MOTHEd FROM KEYBOARD)

Y3: Output of Pre-Feeding

0~1023

This value is calculated by control program. Users can see it and know how the executive unit for pre-feeding works.

Users can set this value from keyboard to directly control the executive unit to work.

Setting this value when device stops, when it is started, the output will be regulated from this value.

Y4: P-Factor in PI Module for Pre-Feeding

0-99.99, General 1-60, Default : =10 Same meaning with Parameter P6.

Y5: T-Factor in PI Module for Pre-Feeding

0-99.99, General 3-20, Default =5 Same meaning with Parameter P7.

About Pre-Feeding:

1. Pre-Feeding is an optional control loop. It is to guarantee well-proportioned materials on the belt. Its calibrated-factor (Y2) adopts static measurement and do not need do often.

2. Goal of Pre-Feeding (Y1) do not need to alter often, even though the Control Target (P1) alters.

3. Define Process of Y1:

a. Determine the value of (Y2), reference to the Parameter Y2 instruction.

b. Open inlet gate in a proper position, manual drive belt running to make the materials to be dragged out to the discharge end. Ensure the shape of materials on the belt to look ideal and no spillover from edge of belt.

c. Watch the value of load of weighing section (Y0). This value can be taken as an ideal goal (Y1).

d. Too large Y1 makes materials pileup on the inlet and too small Y1 makes thinner material layer resulting the speed up running and discharge sloop air-leak (too less material).

e. Parameter C7 must set be "1", C7=1

FX Group Parameters (Calibrate Amplifier)

This group of parameters use by service personal to calibrate amplifier. Not allow anyelse to modify!!!

F0: Zero of Amplifier

0 – 65535

1. Show this parameter F0 .
2. Input a zero signal into amplifier.
3. Press key “Enter”, Analog input reading show.
4. Measure duration determined by A7. System will automatically finish measure when A7 time up and F0 will automatically save and be effective.

F1: Maximum Load of Load Cell

0—99999, Unit Kg, Default =500 Kg

F2: Weighter for Calibration

0—1000, Unit Kg, Default=20 Kg

F3: Maximum Graduation

0—10000, Default=10000

F4: Graduation Coefficient

0—99.9999, Default=6.175

Measure way:

1. Set parameter F1 and set parameter F2 and set parameter F3.
2. Put weighter on load cell. Note: must be the exact weight that parameter F2 refer to.
3. Show this parameter F4, then press key “Enter”, New “F4” shows, Measure finish.

F5: Current Graduation

0—10000

F6: Load of Load Cell

0—Maximum Load (F1), Unit Kg

Function Group

Look for function use the same way with looking for parameter.

Function 1: Print

1. Show this function, then press key “1” to print “Productin Report”.
2. Show this function, then press key “2” to print “Parameter Report”.

Print style like below:

Parameter Report	Production Report
==== PROCESS DATA =====	==== PROCESS DATA =====
QQ (P4) = 341	Goal (P1) = 5555.55kg/Min
KK (P5) = 1684.13	Total (P2) = 999999.999 T
KP (P6) = 10.00	Time: 12: 58: 00 03-03-26
KT (P7) = 10.00	=====
TIME: 12: 58: 00 03-03-26	
=====	

Function2: INIT- Restore All Parameters into default

This function will restore all parameters into default when device dilievey. Only during testing and in case of really need doing this. In normal usage, this function is forbidden in normally usage.

In case of system stoping, select function “INIT”, press key “Enter”, system ask for service personal password. If password is right, all parameters will be restore into default when device dilievery

Function3: JIAN- Self Check (Specially for Service Personal)

In case of system stoping, select function “JIAN”, press key “Enter”, system ask for service personal password. J1-J4 are self check output, Input the value that want executor to fulfil one keyboard and then press key “Enter”, the value will be send to corresponding executor.

- J1=Feeding Control A/D Output**
- J2=Current FlowA/D Output**
- J3=Pre-feeding Control A/D Output**
- J4=Switches Output (one bit to one switch channel)**

Chapter 6 - Appendix

Appendix 1, AX Group Parameters List

Name	Meaning	Format	Range	Unit	Mod	Default	Pass word
P1	Control Target	XXXX. XX	0~9999.99	with C9	Y		N
P2	Total	XXXXX.X	0~999.999	Kg	N		—
P3	Output	XXXX	0~1023	— —	Y		N
P4	Zero	XXXXX	0~99999	— —	Y		Y
P5	Calibration	XXXX.XX	1~9999.99	— —	Y		Y
P6	P	XX.XX	0~99.99	— —	Y	10.00	N
P7	T	XX.XX	0~99.99	— —	Y	5.00	N
P8	Flow Smooth Factor	XXXX	0~9999	— —	Y	0	Y
P9	Inner Accumulative Flow Error	±XXXX.X	0~9999.9	Kg	N	—	—
PP	Speed Coefficient	XXXX	0~9999.99	— —	Y	—	—

Appendix 2, Hx Group Parameters List

Name	Meaning	Format	Range	Unit	Mod	Default	Pass word
H0	A/D	XXXXX	0~65535	— —	N	—	—
H1	Compensation A/D	XXXXX	0~65535	— —	N	—	—
H2	Load cell Supply(+)	XXXX	0~4096	— —	N	—	—
H3	Load cell Supply(-)	XXXX	0~4096	— —	N	—	—
H4	Speed Pulse	XXXX	0~2000	— —	N	—	—
H5	Belt Speed	XX.XXXX	0~99.9999	Meter/s	N	—	—
H6	Load On Belt	XXXX.XX	0~9999.99	Kg	N	—	—
H7	A/D Input for Target set	XXXX	0~4096	— —	N	—	—
H8	Switch Inut	XXXXXX	0=off 1= On	— —	N	—	—

Appendix 3 CX Group Parameters List

Name	Meaning	Format	Range	Unit	Mod	Default	Pass word
C0	Start/Stop Way	X	0=Panel 1= Cabibet 2=Commu	—	Y	0	N
C1	Target Setting Way	X	0= Panel 1=Analog Input 2=Commu	—	Y	0	N
C2	A/D Output Terminal	X	0= Flow 1= Load 2=Belt Speed	—	Y	0	Y
C3	Alarm Limit Way	X	0=Percent 1=Real Flow	—	Y	0	Y
C4	Stop In Case of Alarm	X	0=No Stop 1=Stop After a Delay	—	Y	0	Y
C5	Add Up Condition	X	0=AllTime 1=Only Running	—	Y	0	Y
C6	Controlled Feeder	X	0=Speed Constant 1=Speed Vary	—	Y	—	Y
C7	Control Mode	X	0=Feeding 1=With Pre-Feeding 2=Measure	—	Y	0	Y
C8	Communication	X	00=485 1=PROFIBUS	—	Y	00	Y
C9	System Unit	X	0=kg/Minute 1=ton/Hour 2=Kg/Second 3=G/Second	—	Y	0	Y
CA	Amplify Multiple	X	0-3		Y	0	Y
CB	Compensation	X	0=No 1=Compenstion		Y	0	Y
CC	Trace	X	0=No 1=Trace		Y	0	Y

Appendix 4 AX Group Parameters List

Name	Meaning	Format	Range	Unit	Mod	Default	Password
A0	Maximum Target Setting from A/D	XXXX.XX	0~9999.99	With C9	Y	500	Y
A1	Maximum Flow For A/D Output	XXXX.XX	0~9999.99	With C9	Y	500	Y
A2	Higher Limit	XXXX.XX	1.0~9999.99	% or with C9	Y	20	Y
A3	Lower Limit	XXXX.XX	1.0~9999.99	% or with C9	Y	20	Y
A4	Stop Because Alarm	XXXX	0~9999	Second	Y	60	Y
A6	Pluse For Sub-Total	XXXX	1~9999.99	With C9	Y	1000	Y
A7	Duration of Zero	XXXX	0~9999	Second	Y	10	Y
A8	Duration of Calibration	XXXX	0~9999	Second	Y	10	Y
A9	Password	XXXXXX	000000~999999		Y		Y
AA	Coefficient for Trace	XXX.XX	999.99	%	Y	10	Y
At	Start/Stop Delay	XXXX	0~9999	Second	Y	0	Y
Ab	Belt Length	XX.XXXX	0~99.9999	Meter	Y	10	Y
Ad	Length of Weighing Section	XX.XXXX	0~99.9999	Meter	Y	1	Y
AL	Delay for Feeding	XXXX	0~999	Second	Y	10	Y

Appendix 5 Ex Group Parameters List

Name	Meaning	Format	Range	Unit	Mod	Default	Password
E0	Minimum A/D for Target Input	XXXX	0~4095		Y	0	Y
E1	Maximum A/D for Target Input	XXXX	0~4095		Y	4095	Y
E2	Minimum A/D for Flow Output	XXXX	0~1023		Y	0	Y
E3	Maximum A/D for Flow Output	XXXX	0~1023		Y	1023	Y
E4	Coefficient for load cell compensation	XXXX	0~4095		Y	4095	Y
E5	Coefficient for load cell compensation	XXXX	0~65535		Y	65535	Y
E6	Minimum A/D for Control Output	XXXX	0~1023		Y	0	Y
E7	Maximum A/D for Control Output	XXXX	0~1023		Y	1023	Y
E8	Multiple of Calibration	X	0-4		Y	0	Y
E9	Baud for Communication	X	0-3		Y	3	Y

Appendix 6 Fx Group Parameters List

Name	Meaning	Format	Range	Unit	Mod	Default	Password
F0	Zero of Amplifier	XXXXX	0~65535		Y	0	Y
F1	Maximum Weight for Load Cell	XXXXX	0~99999	Kg	Y	1000	Y
F2	Calibration Weighter	XXX.XX	0~999.99	Kg	Y	20	Y
F3	Maximum Graduation	XXXXX	0~99999		Y	10000	Y
F4	Graduation Coefficient	XX.XXXX	0~99.9999		Y	6.175	Y
F5	Current Graduation	XXXXX	0~99999		N		N
F6	Load on Weighing Section	XXXX.XX	0~9999.99	Kg	N	0	N

Appendix 7 Tx Group Parameters List

Name	Meaning	Format	Range	Unit	Mod	Default	Password
T0	Date	XX.XX.XX	99.12.31	YY.MM.DD	Y		Y
T1	Time	XX.XX.XX	24.59.59	hh:mm:ss	Y		Y
T2	Date of Power On	XX.XX.XX	99.12.31	YY.MM.DD	N		N
T3	Time of Power On	XX.XX.XX	24.59.59	hh:mm:ss	N		N
T4	Date of Power off	XX.XX.XX	99.12.31	YY.MM.DD	N		N
T5	Time of Power off	XX.XX.XX	24.59.59	hh:mm:ss	N		N

Appendix 8 Lx Group Parameters List

Name	Meaning	Format	Range	Unit	Mod	Default	Password
L0	Upper Limit	XXXX.XX	0-9999.99	Kg	Y	500	Y
L1	Bottom Limit	XXXX.XX	0-9999.99	Kg	Y	00	Y
L2	Wait After Load	XXX	0-999	Second	Y	4	Y
L3	Maximum Load Duration	XXX	0-999	Second	Y	60	Y
L6	Coefficient of Control	XXX	0-999	Second	Y	10	Y
L7	Coefficient of Control	XX.XX	0-99.99		Y	1	Y
L8	Alarm Time	XXX	0-999	Second	Y	1	Y

Appendix 9 Ux Group Parameters List

Name	Meaning	Format	Range	Unit	Mod	Default	Password
U0	Goal for Fix Quantify	XXXX. XX	0~9999.99	Kg	Y	100. 00	Y
U1	Total for Fix Quantify	XXXX. XX	0~9999. 99	Kg	N		N

Appendix 10 Yx Group Parameters List

Name	Meaning	Format	Range	Unit	Mod	Default	Password
Y0	Load	XXXX.XX	0~9999.99	kg	N		—
Y1	Goal for Pre-feeding	XXXX.XX	0~9999.99	kg	Y		Y
Y2	K for Pre-feeding	XXXX.XX	0~9999.99	—	Y		Y
Y3	Output for Pre-feeding	XXXX	0~1023	—	Y		N
Y4	P Coefficient	XX.XX	0~99.99	—	Y	10.00	N
Y5	T Coefficient	XX.XX	0~99.99	—	Y	5.00	N

Appendix 11 Ox Group Parameters List

Name	Meaning	Format	Range	Unit	Mod	Default	Password
O0	Active/Stop Flow Section Adjust	X	0=No 1=Active	— —	Y	0	—
O1	Coefficient 1	XX.XXXX	0.9~1.1	— —	Y	0.9	Y
O2	Coefficient 2	XX.XXXX	0.9~1.1	— —	Y	0.95	Y
O3	Coefficient 3	XX.XXXX	0.9~1.1	— —	Y	1.05	N
O4	Coefficient 4	XX.XXXX	0.9~1.1	— —	Y	1.1	N
O5	Auto Print	0=Manual 1=Auto	0-1		Y	0	Y
O6	First Report	XX	0-23 hour		Y	0	Y
O7	Second Report	XX	0-23 hour		Y	0	Y
O8	Third Report	XX	0-23 hour		Y	0	Y
O9	Forth Report	XX	0-23 hour		Y	0	Y

Appendix 12 Function Module List

PRINT	1=Production Report, 2=Parameter Report
INIT	Restore all parameters into default when the device was delivery. Need to input Special password of service personal. Be careful !!!
JIAN	Self Check: Test 3 A/D Outputs and 5 Switch outputs. Need to input Special password of service personal. Be careful !!!

Appendix 3-1、 0405-Wiring Connection 1, 2

Connectivity (1) (3N0405)

接线图 (1)

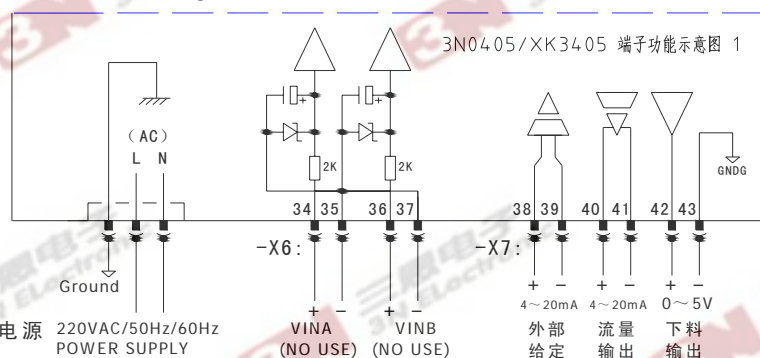

Input Channel 1(External input for Control Target)

Output Channel 1(Flow output)

Output Channel 0(Control)

Connectivity (2) (3N0405)

接线图 (2)

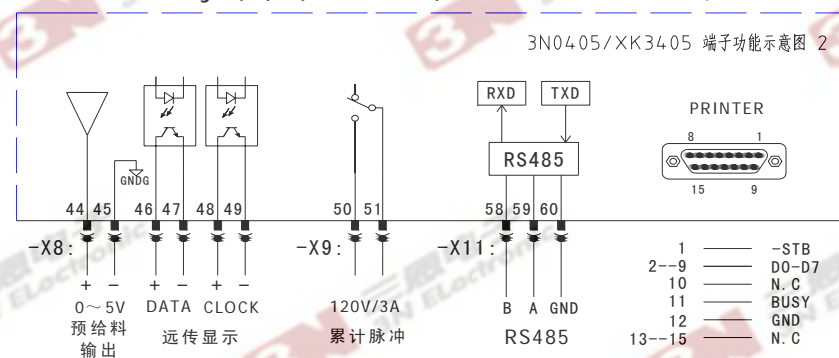

Output Channel 2(Pre-load Control)

Sub-Total Pulse Output

				3N SUNEN 三思电子		名	3N0405-F /XK3405
更改后文件图纸代号		签名	日期	上一级部装(或项目)名称		称	端子功能图 1/2
设计	sunka 8006108120	修改		○添加图纸 ○更改图纸		TEL: 0536-3152451	
审核	lijun	批准		第 张	共 张		

Appendix 3-2: 0405-Wiring Connection 3, 4

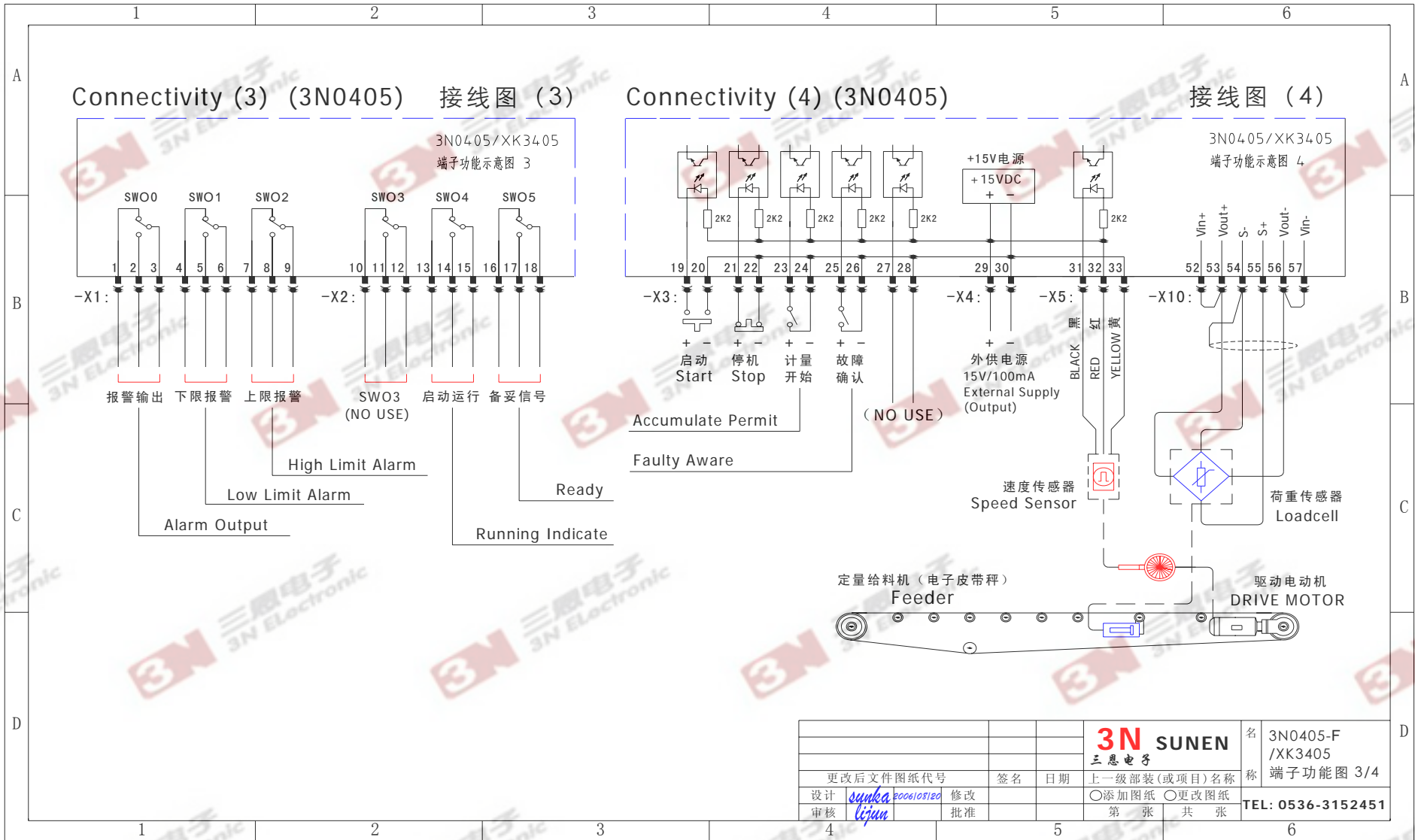

Appendix 3-3: 0405 Wiring To Speed Vary Feeder (Reference)

现场秤体设备端：
Feeder on site:

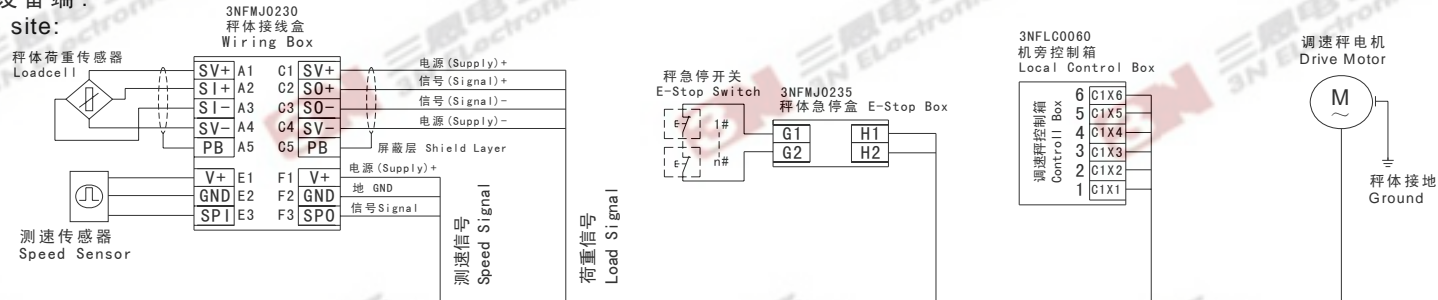

控制柜端：
Cabinet:

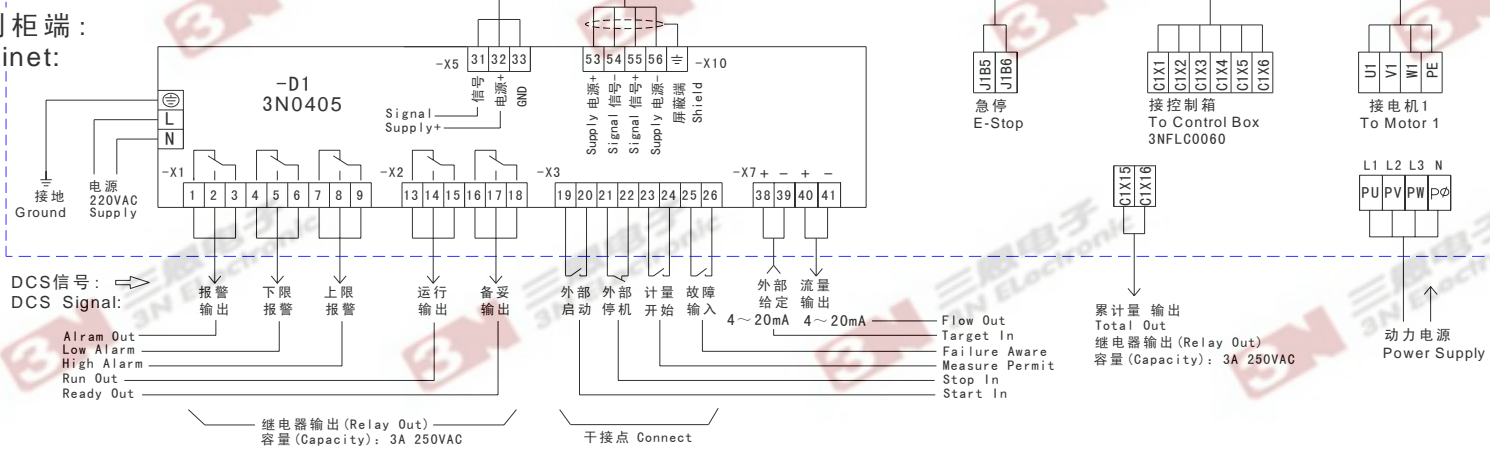

3N 调速秤系统：(接线图例)
3N Feeding System: Wiring and Cable

3N0405

SUNEN 三恩电子
TEL:0536-3152451

Appendix 3-5: 0405 Wiring to Lose-Weight Feeder (3Kg/h ~260 Kg/h) Reference

图 -3N-LCD POWER: 380VAC

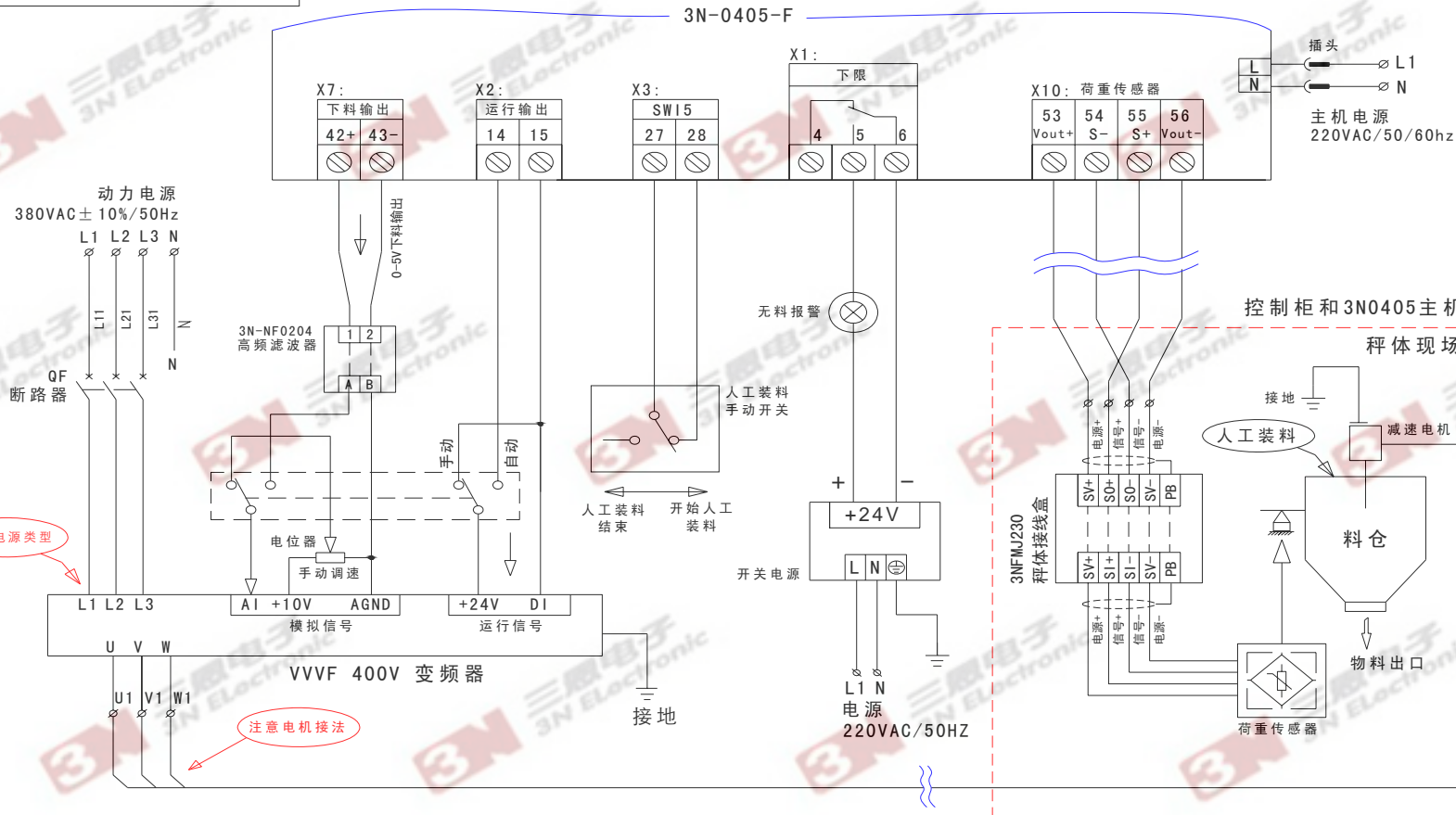

注意电源类型

注意电机接法

注意： 因变频器的不同，动力电源可能用3相4线380V，或2相220V。本图中要特别注意动力电源为380VAC，电动机接法为星形！

<p>3N-LCD 型减量秤系统（人工装料） 控制图（三相四线380V供电） 20080420</p>	<p>SUNEN 三恩电子 TEL:0536-3152451</p>
---	--

Appendix3-5: 0405Wiring to Lose-Weight Feeder(3Kg/h~15000Kg/h) Reference

图 -3N-LCD-B POWER:380VAC

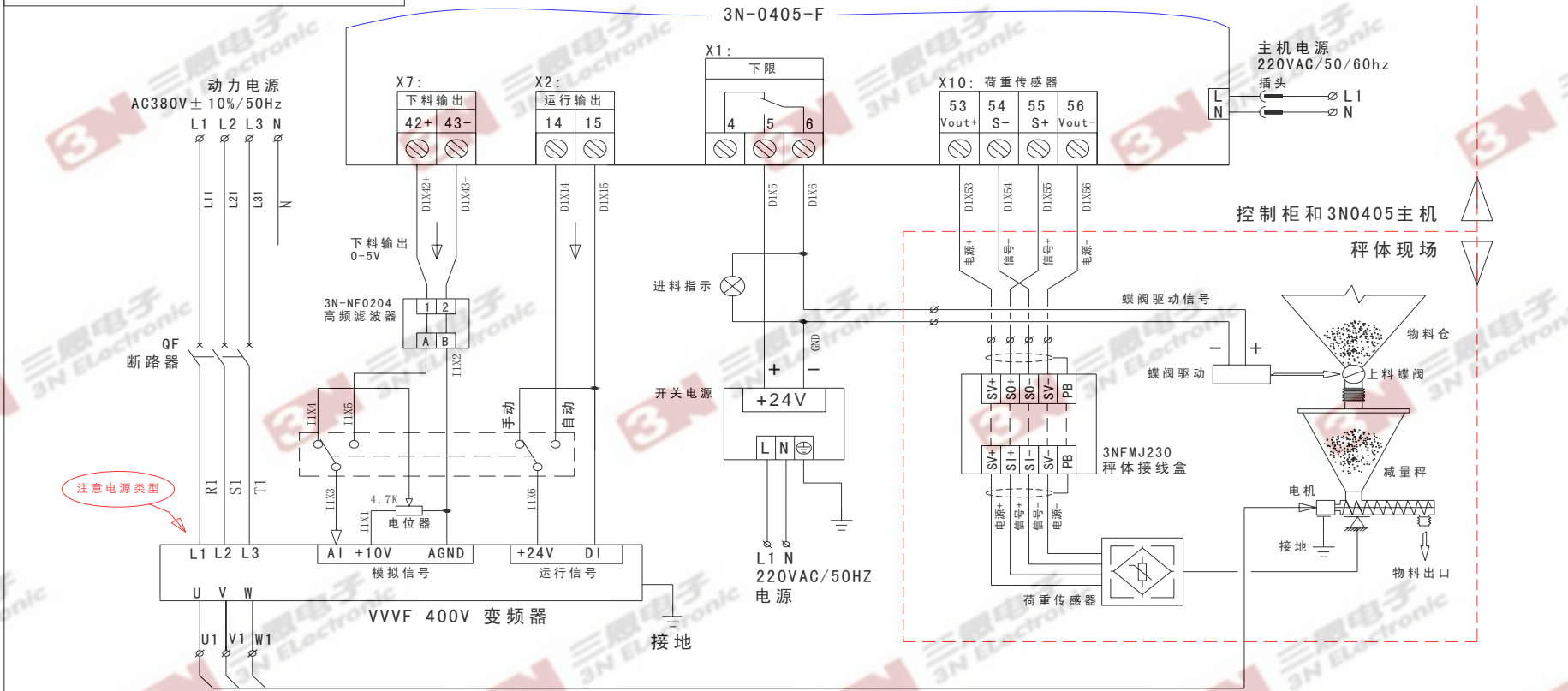

注意电源类型

注意电机接法

注意： 因变频器的不同，动力电源可能用3相4线380V，或2相220V。本图中要特别注意动力电源为380VAC，电动机接线为星形！

3N-LCS-B 型减量秤系统（自动装料）
控制图（三相四线380V供电）

20080420

SUNEN 三恩电子
TEL:0536-3152451

Appendix 3-6: 3N-0405 With Touch Screen (Reference)

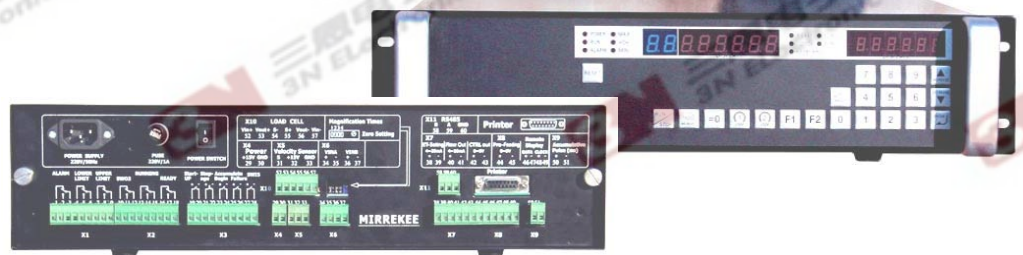
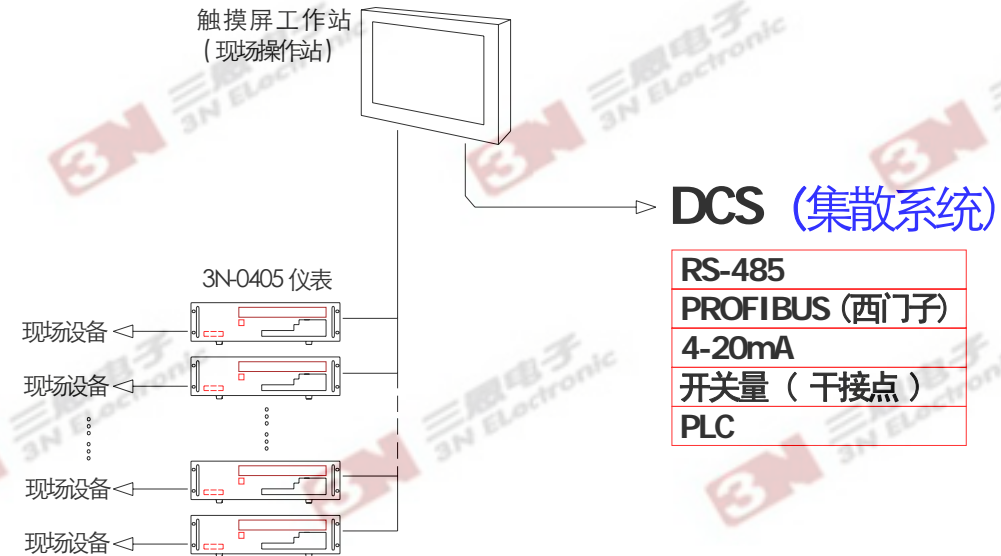

Appendix 3-7: 3N-0405 Appearance Dimension Reference (Cabinet)

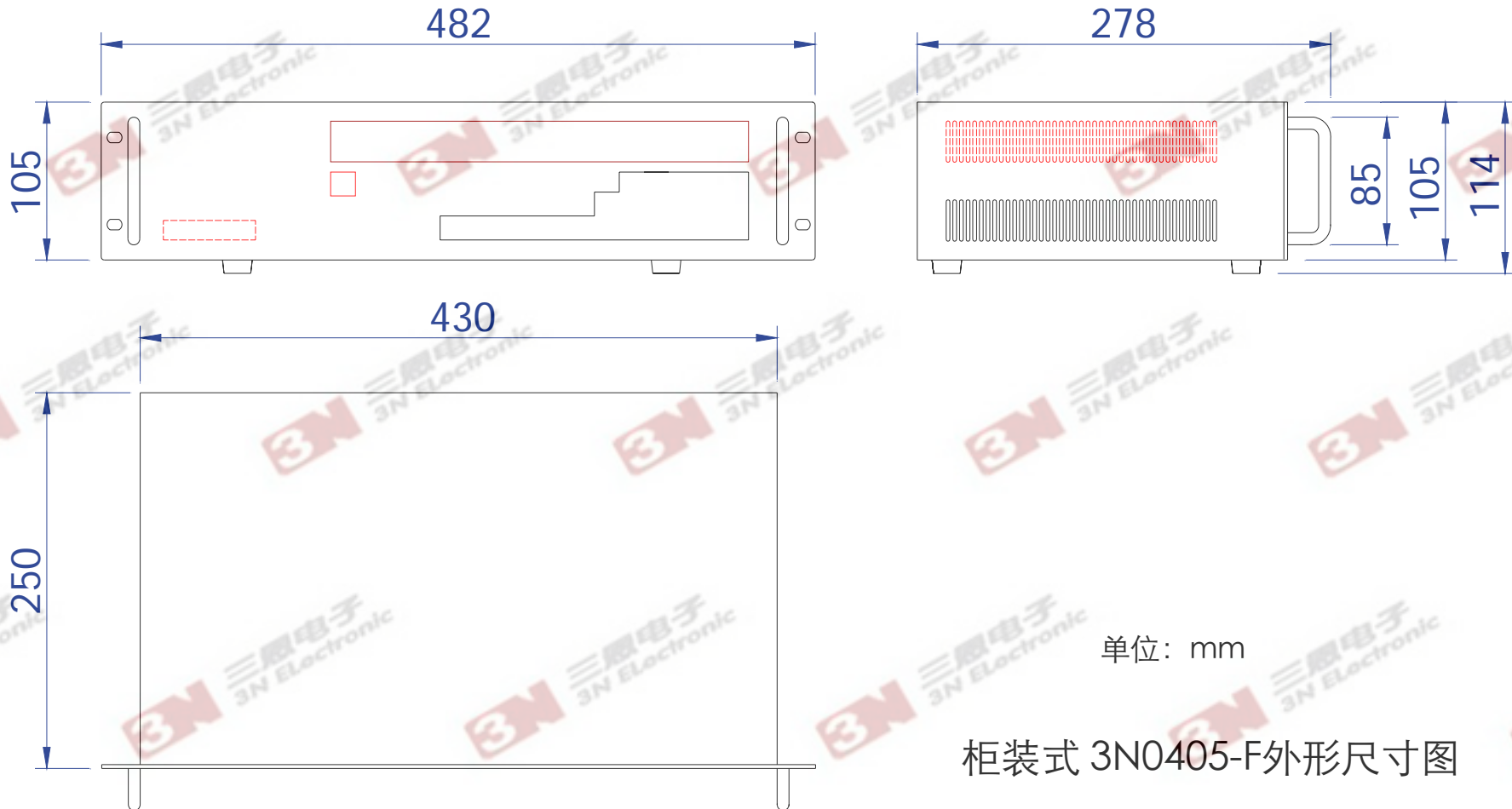

柜装式 3N0405-F外形尺寸图